

# HAFCO METALMASTER

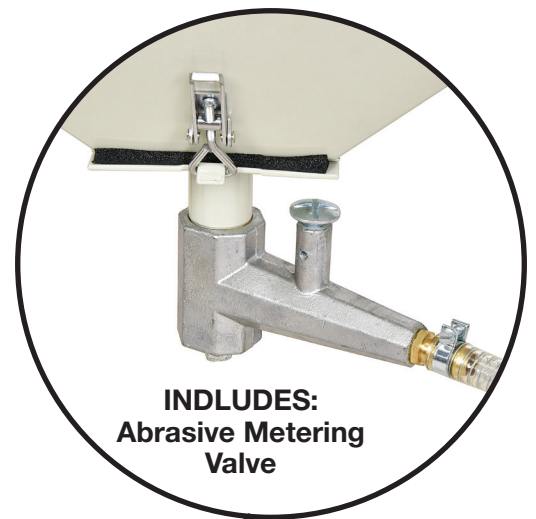

Edition : 1.0  
Date: (05/26)

## Instruction Manual



# SANDBLASTING CABINET SB-220

Order Code: (S290)

**MACHINE DETAILS**

<b>MACHINE</b>	Sandblasting Cabinet
<b>MODEL NO.</b>	SB-220
<b>SERIAL NO.</b>	
<b>DATE OF MANF.</b>	

DISTRIBUTED BY



[www.machineryhouse.com.au](http://www.machineryhouse.com.au)

[www.machineryhouse.co.nz](http://www.machineryhouse.co.nz)

**NOTE:**

*This manual is only for your reference. At the time of the compiling of this manual every effort to be exact with the instructions, specifications, drawings, and photographs of the machine was taken. Owing to the continuous improvement of the HAFCO METALMASTER machine, changes may be made at any time without obligation or notice. Please ensure the local voltage is the same as listed on the specification plate before operating any electric machine.*

**SAFETY SYMBOLS**

The purpose of safety symbols is to attract your attention to possible hazardous conditions



**WARNING** Indicates a potentially hazardous situation causing injury or death



**CAUTION** Indicates an alert against unsafe practices.

**Note:** Used to alert the user to useful information



**NOTE:**

*In order to see the type and model of the machine, please see the specification plate. Usually found on the back of the machine. See example (Fig.1)*

Fig.1

<b>HAFCO</b> <b>METALMASTER</b>	
<b>PRODUCT SPECIFICATIONS</b>	
Model: SB-220	Nett Weight: 46.5kg
MFG Date:	Voltage: 240V/50Hz
	FLC: 0.6A
Serial No:	<input type="text"/>
Imported by <a href="http://www.machineryhouse.com.au">www.machineryhouse.com.au</a>	Made in China <a href="http://www.machineryhouse.co.nz">www.machineryhouse.co.nz</a>

**CONTENTS:**

1.0 GENERAL MACHINE INFORMATION	
1.1 Specifications .....	4
1.2 Includes.....	4
1.3 Machine Dimensions.....	4
1.4 Identification .....	5
2.0 SAFETY	
2.1 General Machine Safety.....	6
2.2 Specific Safety For Sandblast Cabinets .....	9
3.0 POWER SUPPLY	
3.1 Electrical Installation .....	10
3.2 Full-Load Current Rating.....	10
4.0 SETUP	
4.1 Unpacking.....	11
4.2 Clean Up .....	11
4.3 Site Preparation .....	11
4.4 Lifting Instructions .....	11
4.5 Anchoring To The Floor.....	12
4.6 Assembly .....	13
4.7 Attach Dust Collector Unit .....	19
5.0 OPERATION	
5.1 Basic Operation .....	20
5.2 Abrasive Metering Valve.....	23
5.3 Blasting Media .....	24
5.4 Troubleshooting .....	25
6.0 MAINTENANCE	
6.1 Schedule .....	26
7.0 RECOMMENDED ACCESSORIES .....	27
Spare Parts.....	28



**WARNING!**

*The machine is the sole responsibility of the owner for its safe use. This responsibility includes but is not limited to proper installation in a safe environment, personnel training, proper inspection and maintenance, manual availability and comprehension. The manufacturer will not be held liable for injury or property damage from negligence, improper training, machine modifications or misuse.*

## 1.0 GENERAL MACHINE INFORMATION

### 1.1 SPECIFICATIONS

Order Code	S290
<b>MODEL</b>	<b>SB-220</b>
Approx. Inside Cabinet Size (L x W x H) (mm)	870 x 500 x (350-500)
Internal Light (type)	LED Light
Recommended Free Air Delivery (FAD) @ 100psi	15 CFM (425 L/min)
Suggested Operating Air Pressure Range	60 ~ 120psi
Maximum Air Pressure	120psi
Flange Diameter of Dust Collector Inlet	Ø63mm
Floor Space (L x W x H) (mm) with Lid Open	900 x 650 x 1820
Dimensions (W x D x H) (mm) with Lid Shut	900 x 650 x 1400
Nett Weight	46.5kg

### 1.2 INCLUDES

- 5 x Replacement Window Films
- 3 x Spare Ceramic Tips



### 1.3 MACHINE DIMENSIONS

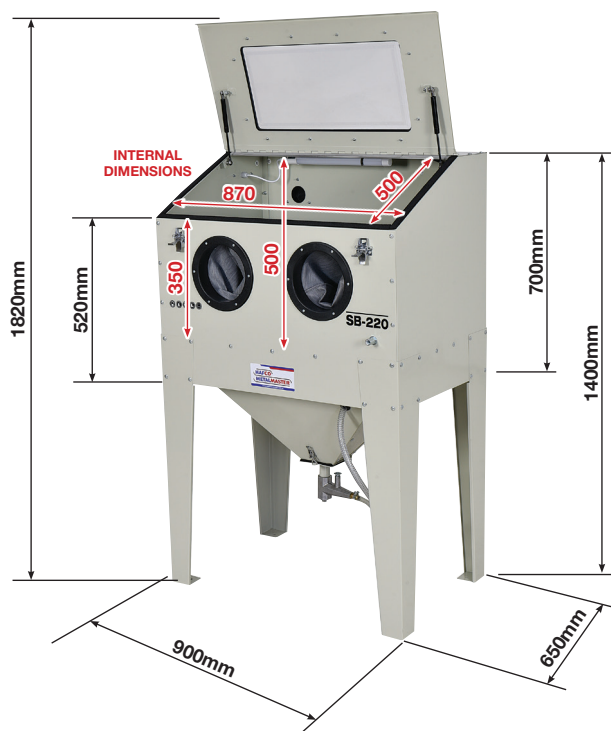

## 1.4 IDENTIFICATION

Become familiar with the names and locations of the controls and features shown below to better understand the instructions when mentioned later in this manual.

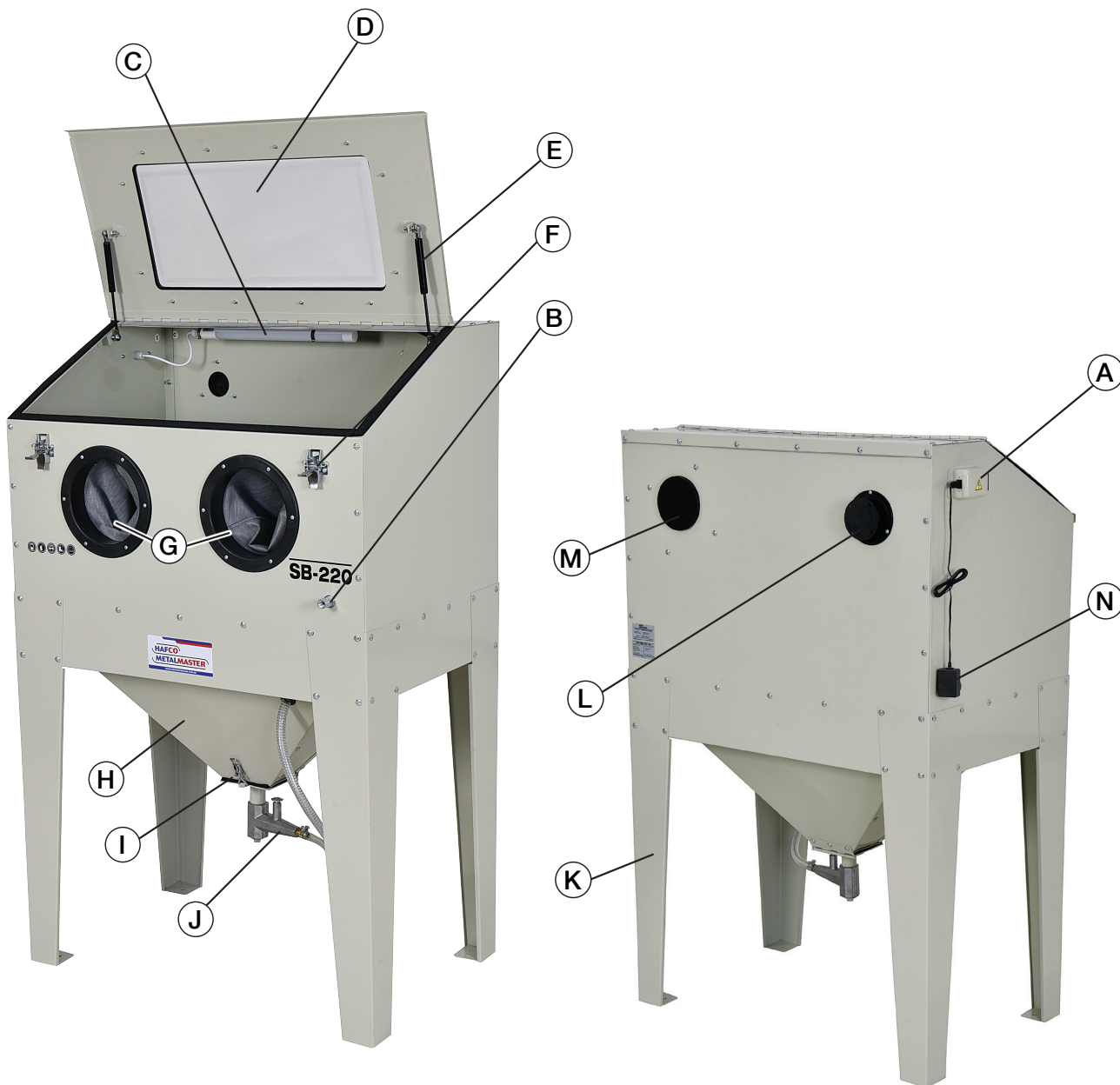

A	ON/OFF Switch - Light	H	Hopper
B	Compressed Air Inlet	I	Hopper Bottom Door
C	LED Light	J	Abrasive Metering Valve
D	Viewing Window	K	Legs
E	Gas Strut Door Operation	L	Dust Collector Ø63mm Outlet - shown with Cap
F	Front Access Door Latch	M	Air Intake Breather - shown with Cap
G	Gloves	N	Power Plug for Light

## 2.0 SAFETY

### 2.1 GENERAL MACHINE SAFETY

DO NOT use this machine unless you have read this manual or have been instructed in the safe use and operation of this machine.



# WARNING!

This manual provides safety instructions on the proper setup, operation, maintenance, and service of this machine. Save this manual, refer to it often, and use it to instruct other operators.

Failure to read, understand and follow the instructions in this manual may result in fire or serious personal injury—including amputation, electrocution, or death.

The owner of this machine is solely responsible for its safe use. This responsibility includes, but is not limited to proper installation in a safe environment, personnel training and authorization to use, proper inspection and maintenance, manual availability and comprehension, of the application of the safety devices, integrity, and the use of personal protective equipment.

The manufacturer will not be held liable for injury or property damage from negligence, improper training, machine modifications or misuse.



- ✓ Always wear safety glasses or goggles.
- ✓ Wear appropriate safety footwear.
- ✓ Wear respiratory protection where required.
- ✓ Gloves should never be worn while operating the machine controls, and only worn when handling the workpiece.
- ✓ Wear hearing protection in areas > 85 dBA. If you have trouble hearing someone speak from one metre (three feet) away, the noise level from the machine may be hazardous.
- ✓ **DISCONNECT THE MACHINE FROM THE POWER** when making adjustments or servicing.
- ✓ Check and adjust all safety devices before each job.
- ✓ Ensure that guards are in position and in good working condition before operating.
- ✓ Ensure all machines have a start/stop button within easy reach of the operator.
- ✓ Each machine should have only one operator at a time. However, everyone should know how to stop the machine in an emergency.

## 2.1 GENERAL MACHINE SAFETY CONT.

- ✓ Ensure that keys and adjusting wrenches have been removed from the machine before turning on the power. Appropriate storage for tooling should be provided.
- ✓ Ensure that all cutting tools and blades are clean and sharp. They should be able to cut freely without being forced.
- ✓ Stop the machine before measuring, cleaning or making any adjustments.
- ✓ Wait until the machine has stopped running to clear cuttings with a vacuum, brush or rake.
- ✓ Keep hands away from the cutting head and all moving parts.
- ✓ Avoid awkward operations and hand positions. A sudden slip could cause the hand to move into the cutting tool or blade.
- ✓ Return all portable tooling to their proper storage place after use.
- ✓ Clean all tools after use.
- ✓ Keep work area clean. Floors should be level and have a non-slip surface.
- ✓ Use good lighting so that the work piece, cutting blades, and machine controls can be seen clearly. Position any shade lighting sources so that they do not cause any glare or reflections.
- ✓ Ensure there is enough room around the machine to do the job safely.
- ✓ Obtain first aid immediately for all injuries.
- ✓ Understand that the health and fire hazards can vary from material to material. Make sure all appropriate precautions are taken.
- ✓ Clean machines and the surrounding area when the operation is finished.
- ✓ Use proper lock out procedures when servicing or cleaning the machines or power tools.

### DO NOT

- ✗ Do not distract an operator. Horseplay can lead to injuries and should be strictly prohibited.
- ✗ Do not wear loose clothing, gloves, neckties, rings, bracelets or other jewellery that can become entangled in moving parts. Confine long hair.
- ✗ Do not handle cuttings by hand because they are very sharp. Do not free a stalled cutter without turning the power off first. Do not clean hands with cutting fluids.
- ✗ Do not use rags or wear gloves near moving parts of machines.
- ✗ Do not use compressed air to blow debris from machines or to clean dirt from clothes.
- ✗ Do not force the machine. It will do the job safer and better at the rate for which it was designed.



### **WARNING!**

*Before operating any machine, take time to read and understand all safety signs and symbols. If not understood seek explanation from your supervisor.*

## 2.1 GENERAL MACHINE SAFETY CONT.

**HAZARDS ASSOCIATED WITH MACHINES include, but are not limited to:**

- Being struck by ejected parts of the machinery
- Being struck by material ejected from the machinery
- Contact or entanglement with the machinery
- Contact or entanglement with any material in motion

**Health Hazards (other than physical injury caused by moving parts)**

- Chemicals hazards that can irritate, burn, or pass through the skin
- Airborne items that can be inhaled, such as oil mist, metal fumes, solvents, and dust
- Heat, noise, and vibration
- Ionizing or non-ionizing radiation (X-ray, lasers, etc.)
- Biological contamination and waste
- Soft tissue injuries (for example, to the hands, arms, shoulders, back, or neck) resulting from repetitive motion, awkward posture, extended lifting, and pressure grip.

**Other Hazards**

- Slips and falls from and around machinery during maintenance
- Unstable equipment that is not secured against falling over
- Safe access to/from machines (access, egress)
- Fire or explosion
- Pressure injection injuries from the release of fluids and gases under high pressure
- Electrical Hazards, such as electrocution from faulty or ungrounded electrical components
- Environment in which the machine is used (in a machine shop, or on a work site)



### **WARNING!**

*Machines are safeguarded to protect the operator from injury or death with the placement of guards. Machines must not be operated with the guards removed or damaged.*

## 2.2 SPECIFIC SAFETY FOR SANDBLAST CABINETS

**DO NOT** use this machine unless you have been instructed in its safe use and operation and have read and understood this manual



*Safety glasses must be worn at all times in work areas*



*Long and loose hair must be contained or restrained*



*Sturdy footwear must be worn at all times in work areas*



*Close fitting/protective clothing must be worn*



*Always wear hearing protection when operating this machine.*



*A mask must be worn when excessive airborne dust is created*

**PERSONAL PROTECTION EQUIPMENT.** Media blasting presents a real hazard of silicosis and other lung contamination injuries! These injuries are permanent and can get worse over time. If you use media blasting equipment without the proper head gear, eye protection, and respirator, your lungs and eyes may become permanently damaged. **DO NOT** use this blast cabinet unless you know how to use it. Protect yourself correctly, and keep all unprotected bystanders away.

**ALWAYS** use approved protective equipment and an acceptable respirator type.

**SAFE MEDIA BLASTING.** Do not use system over the rated PSI or lines and seals may burst and cause injury.

**SAFE DUST EXPOSURE.** To prevent dust exposure, always secure the door(s) before beginning media blasting operations.

**LOADING & UNLOADING.** To prevent accidental blasting injury, disconnect the air supply before loading or unloading the workpiece from the blast cabinet.

**WHEN FINISHED.** To prevent accidental blasting injury, disconnect the air supply when finished with the blast cabinet.

**SAFE ENVIRONMENT.** To avoid media escaping from the cabinet or to prevent an entrapment hazard for animals or children, always close and latch shut the blast cabinet doors when not in use.

**CORRECT LIGHTING.** To prevent ballast overload and possible fire, only install lamps that are the same voltage and wattage.

**MAINTAINING BLAST CABINET.** To prevent accidental contamination of shop air, check the blast cabinet for any leaks before use, and reseal immediately.

**MAINTAINING COMPONENTS.** To prevent accidental contamination or blast injuries, replace tips, hoses, lenses, and gloves when they become worn.



**WARNING** *Some dust created by power sanding, sawing, grinding, drilling, and other construction activities contains chemicals known to cause cancer, birth defects or other reproductive harm. Some examples of these chemicals are:*

- *Lead from lead-based paints.*
- *Crystalline silica from bricks, cement and other masonry products.*
- *Arsenic and chromium from chemically-treated lumber.*

*To reduce your exposure to these chemicals: Work in a well ventilated area with protection*

### 3.0 POWER SUPPLY

#### 3.1 ELECTRICAL INSTALLATION

Place the machine near an existing power source. Make sure all power cords are protected from traffic, material handling, moisture, chemicals, or other hazards. Make sure there is access to a means of disconnecting the power source. The electrical circuit must meet the requirements for 240V.

*NOTE : The use of an extension cord is not recommended as it may decrease the life of electrical components on your machine.*

#### ELECTRICAL REQUIREMENTS

Nominal Voltage.....	240V
Cycle.....	50 Hz
Phase.....	Single Phase
Power Supply Circuit.....	10 Amps

#### 3.2 FULL-LOAD CURRENT RATING

The full-load current rating is the amperage a machine draws when running at 100% of the output power. Where machines have more than one motor, the full load current is the amperage drawn by the largest motor or a total of all the motors and electrical devices that might operate at one time during normal operations.

It should be noted that the full-load current is not the maximum amount of amps that the machine will draw. If the machine is overloaded, it will draw additional amps beyond the full-load rating and if the machine is overloaded for a long period of time, damage, overheating, or fire may be caused to the motor and circuitry.

This is especially true if connected to an undersized circuit or a long extension lead. To reduce the risk of these hazards, avoid overloading the machine during operation and make sure it is connected to a power supply circuit that meets the requirements.



## 4.0 SETUP

### 4.1 UNPACKING

This machine was carefully packaged for safe transport. When unpacking, separate all enclosed items from packaging materials and inspect them for shipping damage. If items are damaged, please contact your distributor.

**NOTE:** *Save all the packaging materials until you are completely satisfied with the machine and have resolved any issues with the distributor, or the shipping agent.*

### 4.2 CLEAN - UP

The unpainted surfaces of the machine have been coated with a waxy oil to protect them from corrosion during shipment. Remove the protective coating with a solvent cleaner or a citrus based degreaser.

Optimum performance from your machine will be achieved when you clean all moving parts or sliding contact surfaces that are coated with rust prevented products.

It is advised to avoid chlorine based solvents, such as acetone or brake parts cleaner, as they will damage painted surfaces and strip metal should they come in contact. Always follow the manufacturer's instructions when using any type of cleaning product.

### 4.3 SITE PREPARATION

When selecting the site for the machine, consider the largest size of workpiece that will be processed through the machine and provide enough space around the machine for operating the machine safely. Consideration should be given to the installation of auxiliary equipment. Leave enough space around the machine to open or remove doors/covers as required for the maintenance and service as described in this manual.

It is recommended that the machine is anchored to the floor to prevent tipping or shifting. It also reduces vibration that may occur during operation.

### 4.4 LIFTING INSTRUCTIONS



*This machine is extremely heavy.*

*Serious personal injury may occur if safe moving methods are not followed. To be safe, you will need assistance and power equipment when moving the shipping crate and removing the machine from the crate.*



On the day that the machine arrives, make sure that a forklift or lifting device, with sufficient capacity is available to unload the machine from the vehicle. Ensure access to the chosen site is clear and that doors and ceilings are sufficiently high and wide enough to receive the machine.



**WARNING.** *Make sure everyone is away from the load before hoisting. The load must be under control when lowering loads or when the load is suspended. Rigging and crane operation must be carried out by persons with approved qualifications.*

#### 4.5 ANCHORING TO THE FLOOR

The machine is best mounted on a concrete slab. Masonry anchors with bolts are the best way to anchor machinery, because the anchors sit flush with the floor surface, making it easy to unbolt and move the machine later, if needed. (Fig. 4.1)

##### Machine Mounting Options

Although it is not required Hafco recommends that you secure your machine to the floor. Masonry anchors with bolts are the best way to anchor machinery, because the anchors sit flush with the floor surface, making it easy to unbolt and move the machine later, if needed. (Fig. 4.1) Other methods of mounting is the use of machine mounts which also help with the levelling of the machine and isolating vibration. (Fig. 4.11)

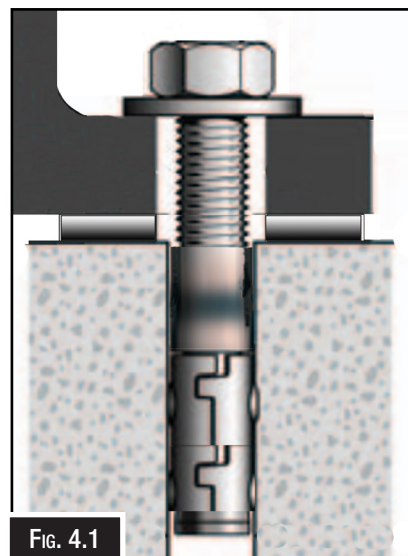

Fig. 4.1

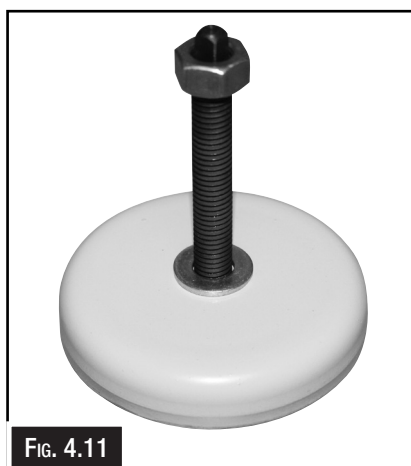

Fig. 4.11



#### **CAUTION!**

*Do not install the machine in areas that are wet, cluttered, or have poor lighting.*



#### **WARNING!**

*The machine is the sole responsibility of the owner for its safe use. This responsibility includes but is not limited to proper installation in a safe environment, personnel training, proper inspection and maintenance, manual availability and comprehension. The manufacturer will not be held liable for injury or property damage from negligence, improper training, machine modifications or misuse.*

## 4.6 ASSEMBLY

### STEP 1

#### Funnel Assembly

- 1). As shown in the figure, position the **back plate (J)** and **front plate (K)** of the funnel so the bent edges align with the mounting holes.
- 2). Apply the **3 x 22mm sealing tape (NN)** along the full length of each bent edge.

**Note:** Allow the sealing tape to **overhang by 10mm** on each end of the edge.

#### HARDWARE USED

(NN) Sealing tape 3 x 22mm 

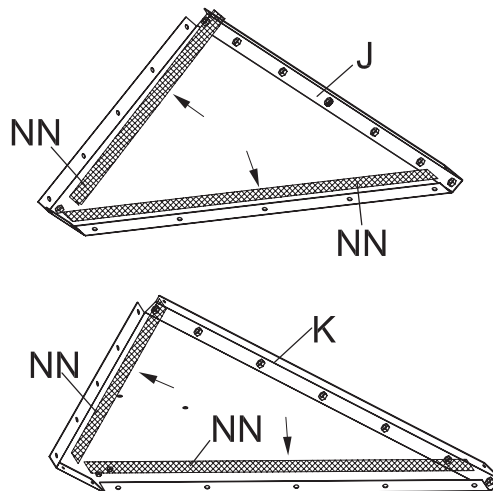

### STEP 2

#### Funnel Assembly

- 1). Using the **M4 x 10mm screws (CC)**, mount the **front plate lock (Z)** onto the **funnel front plate (K)** and tighten the screws.
- 2). Using the **M6 x 12mm screws (AA)**, attach the **funnel front plate (K)** to the **side plate (L)**.

**NOTE:** Ensure sealing tape is applied to **all joints** during assembly.

**Do not fully tighten** the hardware at this stage.

#### HARDWARE USED

(AA) M6x12mm SCREW 5 

(EE) M6 Nut 5 

(CC) M4x10mm SCREW 2 

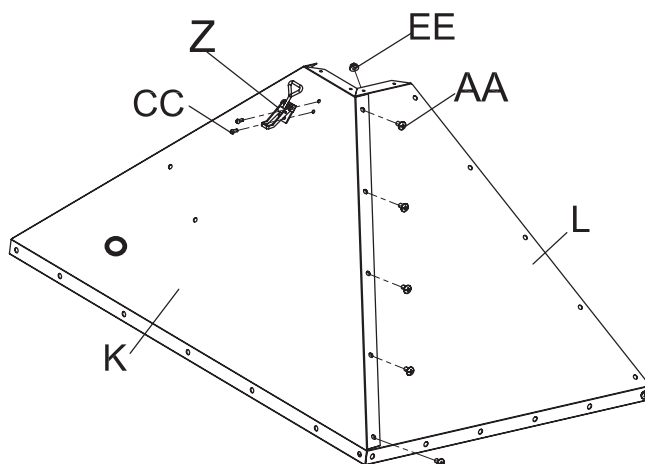

### STEP 3

#### Funnel Assembly

Mount the second side plate (L) to the front plate (K) using M6 x 12mm screws (AA) and M6 nuts (EE).

**NOTE:** Apply sealing tape to **all joints** during assembly.

**Do not fully tighten** the hardware at this stage.

#### HARDWARE USED

(AA) M6x12mm SCREW 5 

(EE) M6 Nut 5 

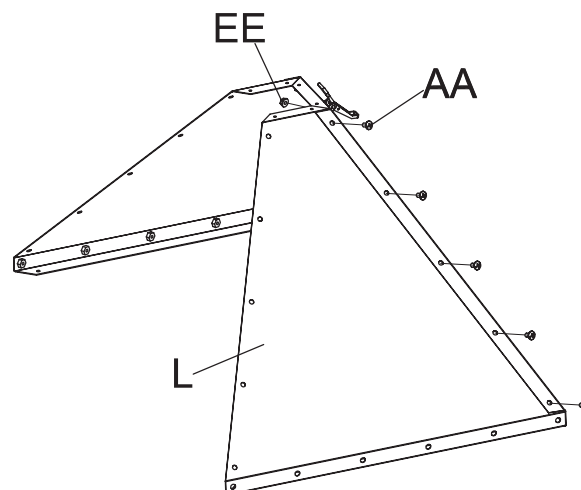

## 4.6 ASSEMBLY CONT.

### STEP 4



#### Funnel Assembly

Mount the **back plate (J)** of the funnel using **M6 x 12 screws (AA)** and **M6 nuts (EE)**.

**NOTE:** Apply sealing tape to **all joints** during assembly.

**Do not fully tighten** the hardware at this stage.

#### HARDWARE USED

- (AA) M6x12mm SCREW 10   
(EE) M6 Nut 10 

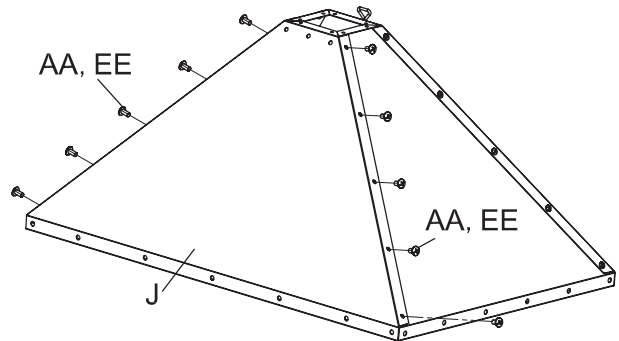





### STEP 5

#### Assemble Funnel Bottom Plate (Y) and Cap (N):

- 1). Tighten the **four screws** on the funnel bottom.
- 2). Apply eight pieces of **3 x 22mm sealing tape (NN)** evenly around the funnel bottom.
- 3). Assemble the **funnel bottom plate (Y)** to the funnel using **M4x10mm screws (CC)** and **washers (GG)**.
- 4). Assemble the **hatch & metering valve (N)** to the **plate (J)** using **M6x12mm screws (AA)**.

#### TIGHTEN SCREWS

#### HARDWARE USED

- (AA) M6x12mm SCREW 3   
(CC) M4x10mm SCREW 8   
(GG) 4 Flat Washer 8   
(NN) Sealing tape 3 x 22mm 

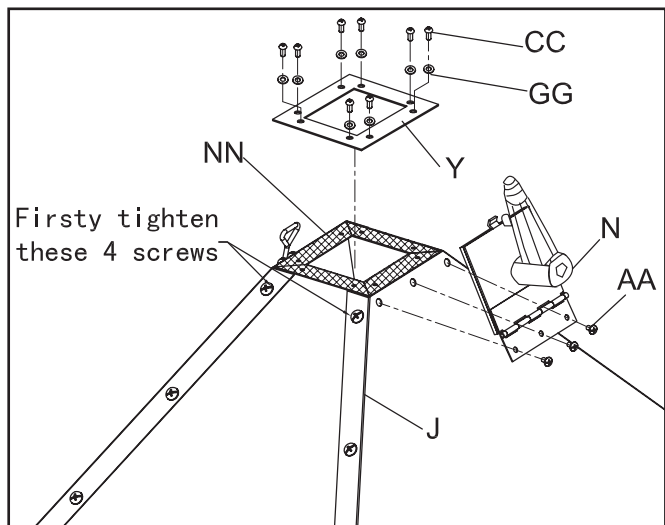



### STEP 6

#### Assembly – Funnel Corner Connection Piece (P)

- 1). Fit the **bracket (P)** to each of the four funnel corners using the **M4x10mm screws (CC)** and **washers (GG)**. Tighten all screws securely.
- 2). Ensure all screws along the **bevel edges** of the funnel are fully tightened.

#### TIGHTEN ALL SCREWS BEFORE PROCEEDING

#### HARDWARE USED

- (CC) M4x10mm SCREW 8   
(GG) 4 Flat Washer 8 

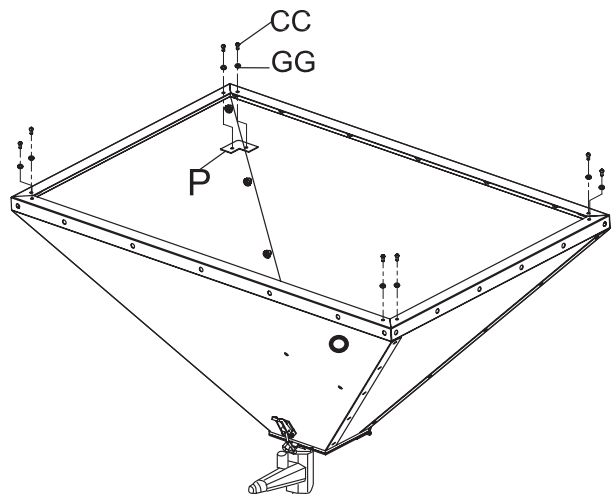

**4.6 ASSEMBLY CONT.**

**STEP 7**

**Apply Sealing Tape (3 × 22mm)**

As shown in the figure, apply the **3 × 22mm sealing tape** along the outer edge of **plate (L)**. Ensure the tape is firmly pressed down along the entire length. At each funnel corner, extend and fold the sealing tape over the edge by **no less than 30mm** to ensure a proper seal.

**HARDWARE USED**

(NN) Sealing tape 3x22mm 

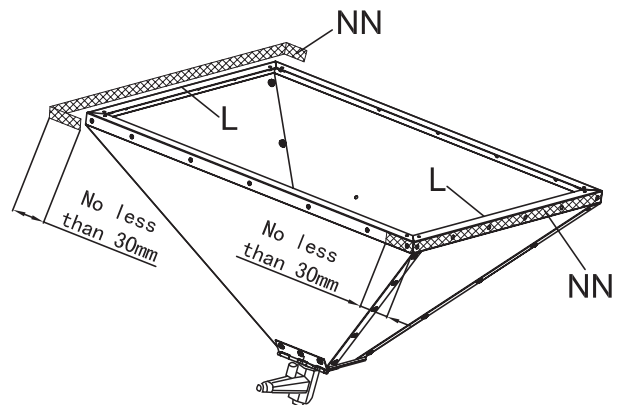

**STEP 8**

**Assemble Left Cabinet Plate (E) to Funnel Assembly**

- 1). Insert the **M6×12mm screws (AA)** through the **two middle holes** of **plate (E)** and into the funnel assembly. Do not fully tighten at this stage.
- 2). Ensure **plate (E)** is positioned in the correct direction before continuing with the remaining screws.

**DO NOT FULLY TIGHTEN THE SCREWS YET**

**HARDWARE USED**

(AA) M6x12mm SCREW 2 

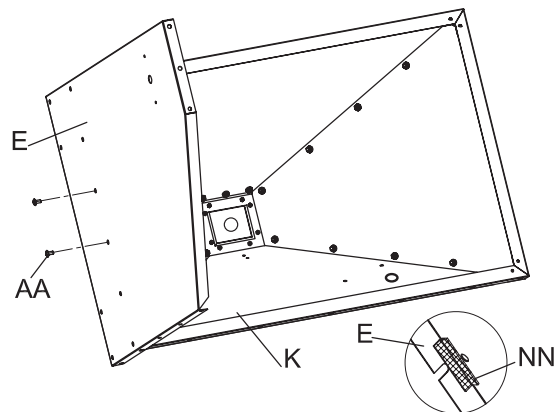

**STEP 9**

**Assemble Right Cabinet Plate (I) to Funnel Assembly**

- 1). Insert the **M6×12 screws (AA)** through the **two middle holes** of **plate (I)** into the funnel assembly.
- 2). Ensure **plate (I)** is positioned in the correct direction before proceeding.

**DO NOT FULLY TIGHTEN THE SCREWS YET**

**HARDWARE USED**

(AA) M6x12mm SCREW 2 

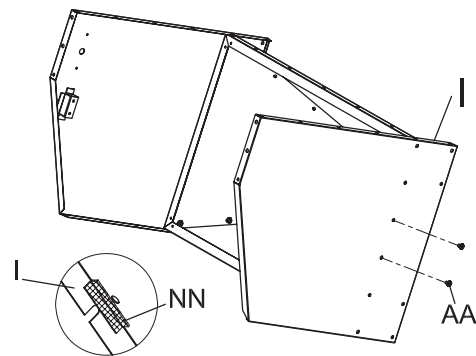

**STEP 10**

**Apply Sealing Tape (3 × 22mm)**

As shown in the figure, apply the **3 × 22mm sealing tape** along the edges of the **back plate** of the **funnel (J)**, as well as the **left (E)** and **right (I) cabinet plates**. Press the sealing tape firmly to ensure it adheres properly and provides a complete seal.

**HARDWARE USED**

(NN) Sealing tape 3 x 22mm 

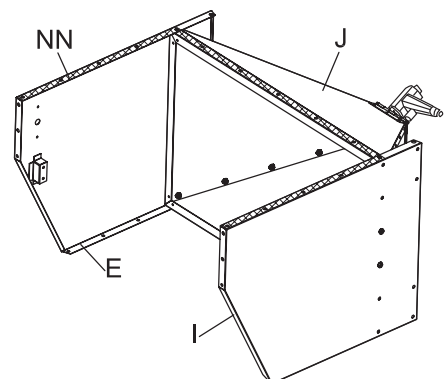



## 4.6 ASSEMBLY CONT.

### STEP 11

#### Back Plate and Foot Assembly:

- 1). Position the **back plate (C)** and **foot (G)** on the cabinet.
- 2). Secure them to the funnel assembly using the **M6x12mm screws (AA)** and **M6 nuts (EE)**.
- 3). Note: Begin by tightening the three middle screws of the **back plate (C)** first.
- 4). Once aligned, tighten all screws securely.

#### HARDWARE USED

- (AA) M6x12mm SCREW 27 
- (EE) M6 Nut 16 

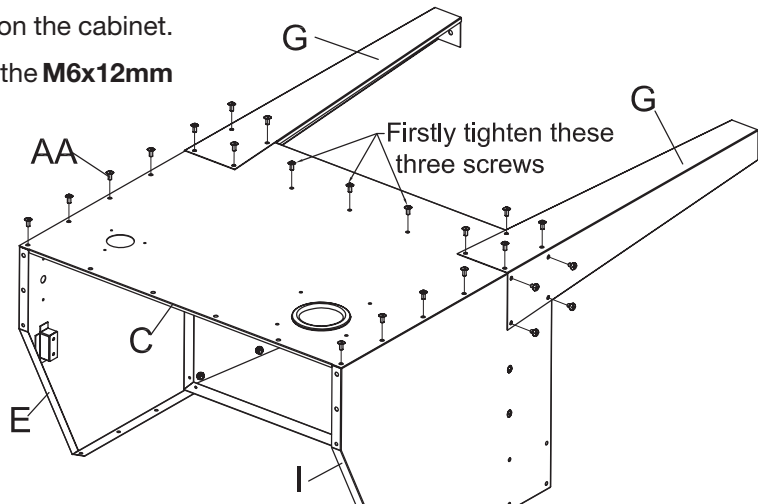

### STEP 12

#### Apply Sealing Tape (3 x 22mm)

Refer to the figure and carefully attach the **five pieces of 3 x 22mm sealing tape** to the **front plate of the funnel (J)**, the **left cabinet plate (E)**, and the **right cabinet plate (I)**, pressing each piece firmly to ensure a secure and effective seal.

#### HARDWARE USED

- (NN) Sealing tape 3 x 22mm 

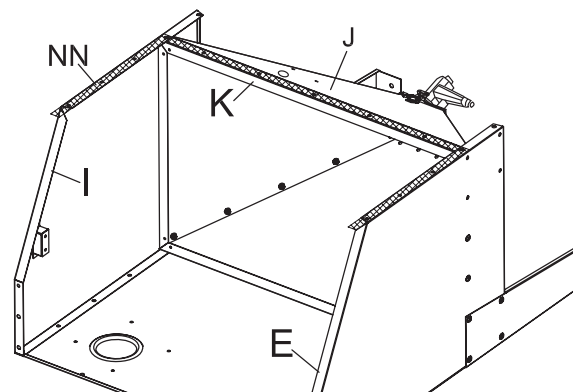

### STEP 13

#### Assemble the Front Plate for Cabinet (C) and Foot (G):

- 1). Attach the **front plate (C)** to the **foot (G)** using the **H6x12mm screws (AA)** and **H6 nuts (EE)**.
- 2). Important: Start by tightening the three middle screws of the **front plate (C)** first.
- 3). Once aligned, tighten all remaining screws securely.

#### HARDWARE USED

- (AA) M6x12mm SCREW 25 
- (EE) M6 Nut 14 

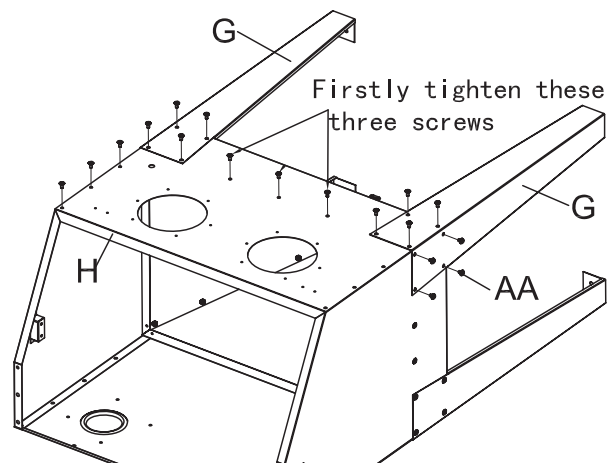

## 4.6 ASSEMBLY CONT.

### STEP 14

#### Assemble Work Shelf (B), Sand Pickup Hose (O), and Sand Blasting Gun (W):

- 1), Place the work shelf (B) inside the cabinet.
- 2), From inside the cabinet, pull the clear **sand pickup hose (O)** through the hole in the grate at the front-right corner.
- 3), Feed the **hose (O)** through the **rubber grommet** at the front of the hopper. Apply a small amount of light **oil** to ease installation if required. Connect the **hose** to the **metering valve** and secure firmly with the supplied **hose clamp**.
- 4), Connect the air hose nipple through **panel (H)**, placing washers on both sides of the panel.
- 5), Attach the **nut and fitting** on the outside of the panel as required.
- 6), Apply **Teflon tape** to all threaded connections to ensure a tight seal.

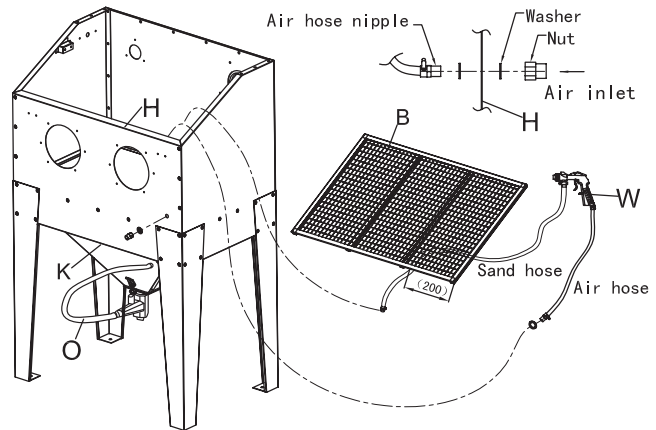



### STEP 15

#### Assemble the Glove Seat (V) and Gloves (R):

- 1), Attach the **glove rings (U)** and **glove seats (V)** to the front of the cabinet (H) using **M4x16mm screws (BB)**, **M4 nuts (FF)**, and four **flat gaskets (GG)**.
- 2), Secure **gloves (R)** to the **glove seats (V)** using the **clamps (S)**.
- 3), **Important:** Tighten all screws securely.

#### HARDWARE USED

- (BB) M4x16mm SCREW 12 
- (FF) M4 Nut 12 
- (GG) 4 Flat Washer 12 

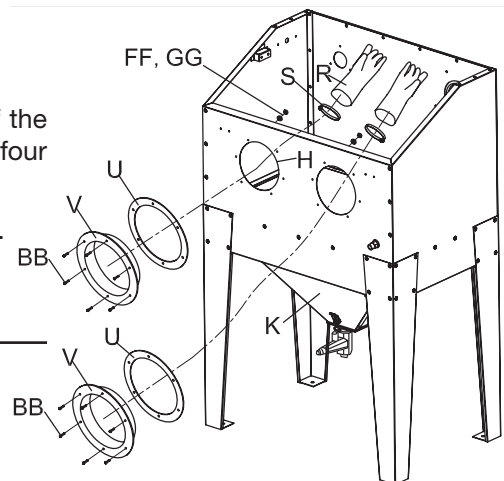







### STEP 16

#### Assemble Suction Flange Ring (KK), Suction Board (X), and Lock (M):

- 1), Attach the suction **flange ring (KK)** to the back of the cabinet (C) using **M4x16mm screws (BB)**, **M4 nuts (FF)**, and **M4 flat washers (GG)** as shown in the figure.
- 2), Install the **suction board (X)** to the back of the cabinet (C) using **M6x12mm screws (AA)** and **M6 nuts (EE)** as shown in the figure.
- 3), Mount the **lock (M)** to the **front plate** of the cabinet (H) using **M4x10mm screws (CC)**, **M4 nuts (FF)**, and **M4 flat washers (GG)** as shown in the figure.
- 4), **Important:** Tighten all screws securely.

#### HARDWARE USED

- |  |   |
|--|---|
| (AA) M6x12mm SCREW 4        | (EE) M6 Nut 4          |
| (BB) M4x16mm SCREW 3        | (FF) M4 Nut 7          |
| (CC) M4x10mm SCREW 4        | (GG) M4 Flat Washer 7  |
| (KK) Suction flangering 10  |   |

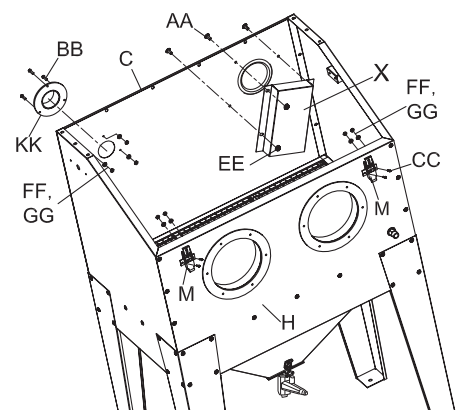

**4.6 ASSEMBLY CONT.**

**STEP 17**

**Apply Sealing Tape (3 x 22mm)**

As shown in the figure, apply the **3 x 22mm sealing tape** to the left plate of the **cabinet (E)**, the top edge of the right plate of the **cabinet (I)**, and the upper rear edge of the back of the **cabinet (C)**.

**Note:** Ensure all corners are fully covered with sealing tape.

**HARDWARE USED**

(NN) Sealing tape 3 x 22mm 

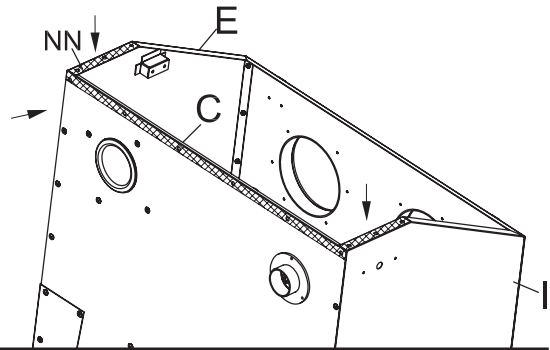









**STEP 18**

**Assemble the Top Plate of Cabinet (D), Lamp (Q), Switch Box (F), etc.:**

- 1), As shown in the figure, install the **lamp clamp (HH)** onto the top plate of the **cabinet (D)** using **M4x6mm screws (DD)**, **M4 nuts (FF)**, and **M4 flat washers (TT)**.
- 2), Place the **lamp (Q)** into the **lamp clamp (HH)** and fasten **nylon cable ties (II)** as illustrated.
- 3), Install the **top plate (D)** onto the cabinet using **M6x12mm screws (AA)** and **M6 nuts (EE)**.
- 4), Connect the **lamp (Q)** wiring to the **switch (F)**, ensuring the wire colors match correctly.
- 5), Install the **switch box (F)** onto the left plate of the **cabinet (E)** using **M4x10mm screws (CC)**, **M4 nuts (FF)**, and **M4 flat washers (GG)**. Note: Ensure the switch button faces the operator.

**TIGHTEN ALL SCREWS.**

**HARDWARE USED**

- (AA) M6x12mm SCREW 10 
- (CC) M6 Nut 10 
- (DD) M4x10mm SCREW 2 
- (EE) M4x6mm SCREW 2 
- (FF) M4 Nut 4 
- (GG) M4 Flat Washer 2 
- (TT) M4 Spring Washer 2 
- (HH) Lamp clamp 2 
- (II) Nylon cable tie 2 

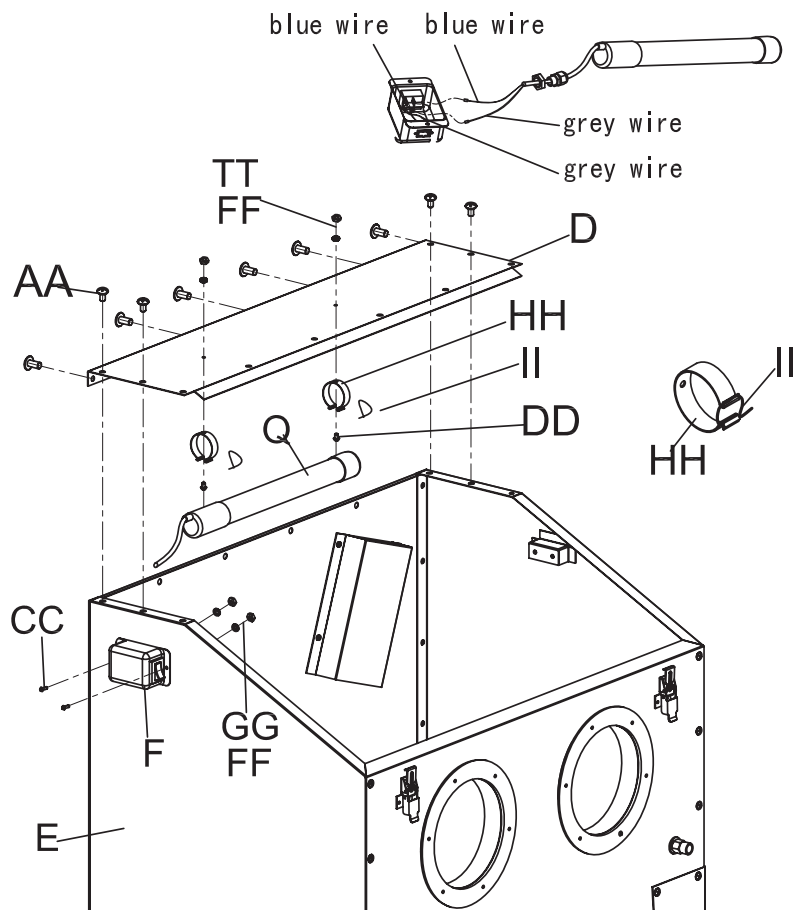

## 4.6 ASSEMBLY CONT.

### STEP 19

#### Apply Sealing Tape (3 x 22mm)

As shown in the figure, apply the **sealing tape** as required to the following areas: the **doorframe of the top plate of the cabinet (D)**, the **front plate of the cabinet (H)**, the **left side plate of the cabinet (E)**, and the **right side plate of the cabinet (I)**. Apply the **3 x 22mm sealing tape (NN)** to the folded edge of the doorframe, and apply the **6 x 22mm sealing tape (JJ)** to all remaining edges of the doorframe.

#### HARDWARE USED

(NN) Sealing tape 3 x 22mm 

(JJ) Sealing tape 6 x 22mm 

(NN) = 3mm

(JJ) = 6mm

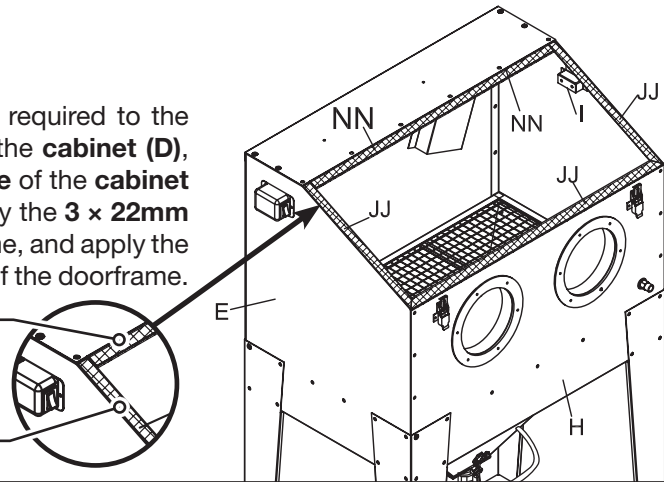

### STEP 20

#### Assemble the Top Door Assembly (A) and Adaptor (QQ):

- 1), Install the **top door assembly (A)** onto the cabinet using **M6x12mm screws (AA)** and **M6 nuts (EE)**.
- 2), Fix the **air struts (T)** to the cabinet using a spanner.
- 3), Plug the **adaptor (QQ)** into the **switch box (F)**.

#### TIGHTEN ALL SCREWS.

#### HARDWARE USED

(AA) M6x12mm SCREW 6 

(EE) M6 Nut 6 

(QQ) Adaptor 1 

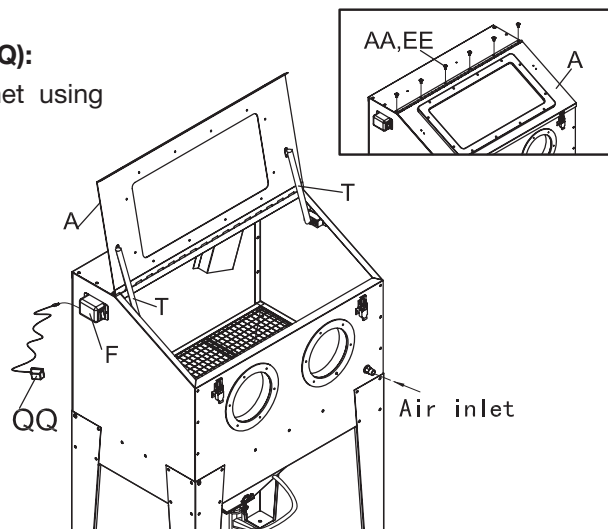

### FINAL CHECKS!

At this stage, recheck that all nuts, bolts, and fasteners are properly tightened.

## 4.7 ATTACH DUST COLLECTOR UNIT (NOT SUPPLIED)



### WARNING!

This machine must be used with a dust collector that is suitable for filtering sandblast media.

The dust collector must be turned on at all times while the sandblaster is in operation.

#### Fitting the Dust Collector: (Fig. 4.6)

- 1). Remove the plastic cap if fitted from the suction inlet (S).
- 2). Attach the dust collector suction hose to the Ø63 mm inlet and ensure it is securely fitted.
- 3). Remove the air inlet cover cap if fitted (T).

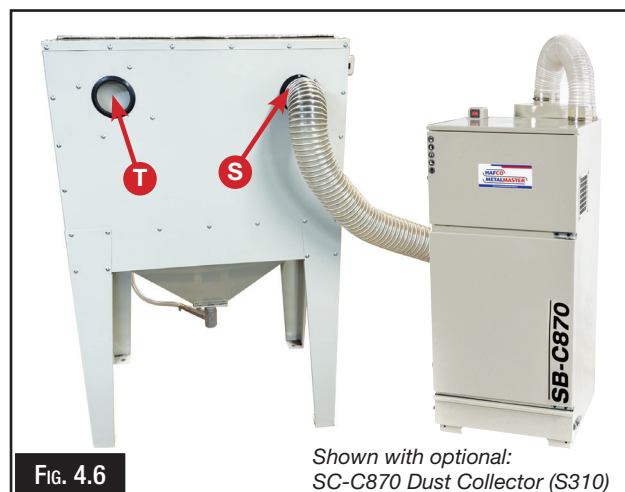

Fig. 4.6

Shown with optional:  
SC-C870 Dust Collector (S310)

## 5.0 OPERATION

### 5.1 BASIC OPERATION

Listed below is the order in which a normal operation for the SB-220 Blast Cabinet is carried out.

**NOTE:** Before using the blast cabinet the first time, fit the window protective film to the inside of the glass windows if not factory fitted.

1. Check the window protective film for holes or excessive etching. Replace the sheets BEFORE they are worn through and the window is damaged.
2. Inspect all fittings and hoses for leaks. Inspect for damaged or leaking door seals. Make sure any water separators are drained and make sure the dust collector is empty and the filter is clean.
3. Put on safety goggles and a respirator.

**NOTE:** To reduce your exposure to Dust Particles: Work in a well ventilated area, and work with approved safety equipment, such as those dust masks that are specially designed to filter out microscopic particles.

4. Select and install the required tip into the blast gun. (Usually 6mm) (Fig. 5.1)

**NOTE:** Tips available for this machine are 4, 5, 6 & 7mm. As a general rule, your nozzle orifice minimum should be 3 times the size of the grit. When media blasting thin materials made of aluminum, copper, brass, wood, or other delicate parts, select the correct media and begin blasting at a low pressure, such as 45PSI. Next, slowly increase the air pressure until you achieve the finish required. When using some types of glass bead media, you may have to keep the operating pressure between 60-80PSI, or the media will break down prematurely.

Some media like silicon carbide and aluminium oxide can withstand pressures of up to 120PSI on this machine; however, most media blasting operations should occur at 80PSI.

6. Turn the regulator knob on your compressor to adjust the air pressure to the desired setting. This is a trial and error process, but a good place to start is a pressure between 90-120PSI.



#### Changing the Nozzle: (Fig. 5.1)

1. Release the Nozzle Nut (P) and remove the nozzle.
2. Replace the nozzle with the desired size.
3. Re-fit and tighten the nozzle nut (P) securely.



#### **DANGER!**

*It is impossible to cover all possible hazards. All operational environments are different. Never use media that contains free silica, as this is a leading cause of silicosis. Always consider safety first, as it applies to the individual working conditions.*

### 5.1 BASIC OPERATION CONT.

7. Clean the workpiece of any oil or grease and place in the blast cabinet. Close the doors, then move the latches until the doors are completely locked.
8. Connect a dust collector to the sand blaster cabinet. Must be turned on and used at all times. (Fig. 5.2)

**NOTE: Dust collector is NOT supplied.**

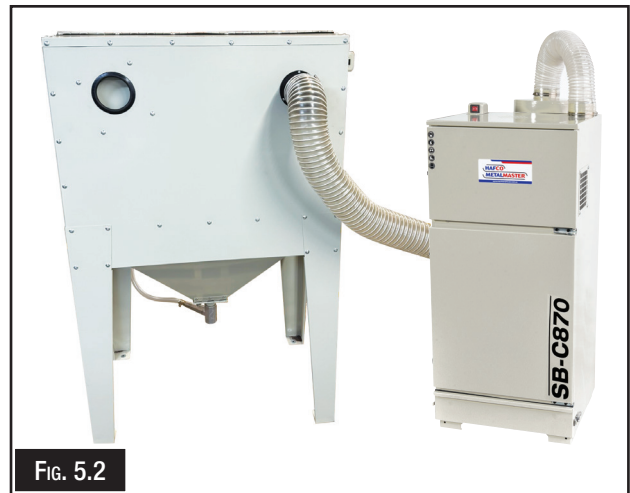

FIG. 5.2

9. Plug the power transformer from the light switch into the 240V power supply. (Fig. 5.3)

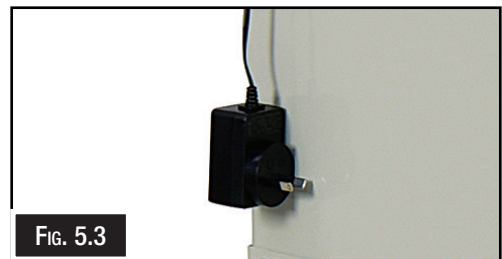

FIG. 5.3

10. Switch on the light. (Fig. 5.4)



FIG. 5.4

11. Connect the blast cabinet to the air supply (H), ensuring the air pressure from the source is between 60–120psi. (Fig. 5.5)  
**NOTE:** Connection fittings are not supplied.

**WARNING: Do not connect to high pressure bottle gas, rupture and explosion can occur.**



FIG. 5.5

## 5.1 BASIC OPERATION CONT.

12. Close and latch the cabinet door.
13. Pull the trigger on the sandblast gun to confirm that air flows correctly from the nozzle. (Fig. 5.6)
14. Open the cabinet door and add the selected media into the hopper through the floor grate approximately 250mm above the metering valve. (Fig. 5.7)

**NOTE: Never use media that contains free silica, as this is a leading cause of silicosis.**

Your unit is now ready for safe operation.

15. Grip the hand gun (Fig. 5.6). Direct gun at parts at 45-60 degree angle with ricochet towards the back of the cabinet. Do not hold gun at 90 degree angle to parts being processed. This will cause the media blast to bounce back into the blast stream and slow blasting action. Also 90 degree angle will cause excessive wear on gun and viewing window. Hold gun approximately 6 inches from parts being blasted.

**The gun must always be pointed away from the operator and towards items being processed. Never blast with any of the cabinet doors open. While loading and unloading, no one should be at the operator station, at the front of the blast cabinet.**

16. Pull gun trigger (Fig. 5.6) and abrasive media will begin spraying from the blast gun tip. Move the blast gun in a slow circular motion when operating.
17. The blasting media can be changed by releasing the bottom hatch in the base of the hopper. (Fig. 5.8)

Operation may require **trial and error**, including adjustment of air pressure, media type, gun tip size, and metering valve settings. A larger gun tip will produce a wider spray area but will require more air and readjustment of the metering valve between tip sizes. **Always ensure the sandblast gun and metering valve are correctly adjusted for optimal performance.**



FIG. 5.6



FIG. 5.7



FIG. 5.8



### **WARNING!**

**Compressed Air is Dangerous and can cause Death or Injury if misused. Always bleed off the airline before disconnecting from the compressor or machine. DO NOT use compressed air to blow dust from clothes.**

## 5.2 ABRASIVE METERING VALVE (Fig. 5.9)

The metering valve may require fine adjustment to achieve optimum performance, depending on the type of media and nozzle size used.

1. **Start the sandblaster** with the foot pedal pressed. While operating, look underneath the machine and observe the clear supply tube leading up to the unit (I).
2. **Fully close the metering bolt** by screwing it all the way in (J).
  - In this position, with the foot pedal still pressed, the media will collect, surge and pulse.
  - This indicates that too much media is being drawn in and not enough air is being mixed with it in the riser tube.
3. **Slowly open the metering bolt (J)** until the blasting media begins to move smoothly and steadily through the riser tube.
  - Continue opening the valve (J) until the surging and pulsing stop.
  - Around this position, the flow can be fine-tuned for best performance.
4. **Avoid over-opening the valve.**
  - If opened too far, the flow of grit will decrease and eventually no media will be drawn through the system.

**NOTE:** To prevent the metering bolt (J) from moving out of adjustment due to vibration, it is recommended to apply a small amount of “**low-strength, removable thread locker**” to the internal thread (K).

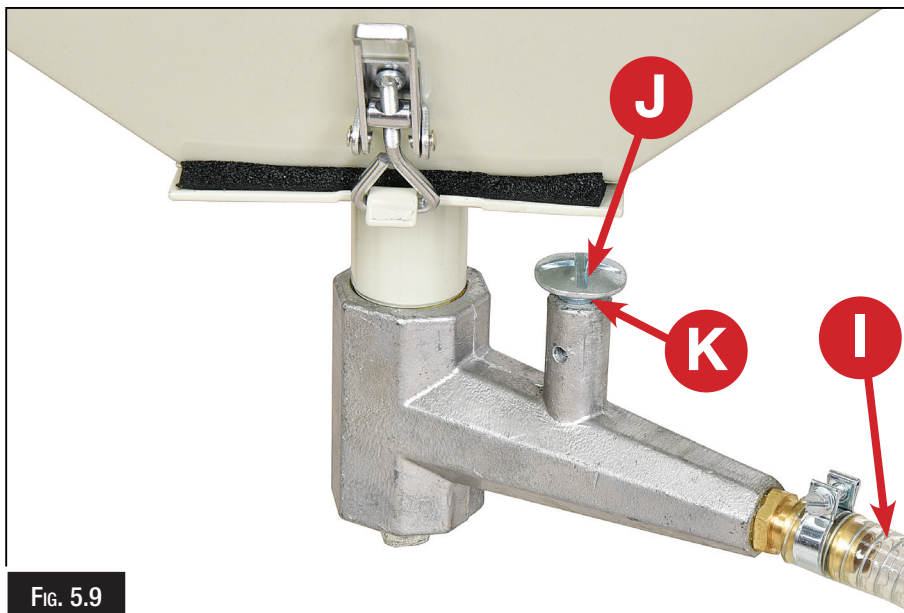

FIG. 5.9



### **WARNING!**

**NEVER** use the sand blast cabinet with the door open, or point the gun at yourself or anyone else. When servicing this machine disconnect the power and the air hose. Ignoring this warning may lead to severe injury.

### 5.3 BLASTING MEDIA

Using low-cost media, such as basic builder's sand or play sand, is not recommended since sand is dull and does not have the cutting power. Excellent productivity can be achieved using sharp media listed below. Media should be of good quality and dry. Moisture will cause the media not to flow and will clog metering valve and hopper.

#### GARNET

Depending on your required finish, there is an ideal garnet grain size for your job. Here's what to know. For general applications when a surface profile above 75 microns is specified, the 30/60 mesh garnet abrasive is the ideal industry standard garnet grade. When you remove thick, soft coatings, the surface may absorb the energy before the garnet grains achieve full impact potential. Therefore, the heavier features of larger grain garnet can be more effective. For this application 20/40 grit size is available.

#### INDA GLASS BEAD

Bead blasting is one type of shot blasting. This process releases, at high pressure, fine glass beads to clean or finish a surface. In this process, a bead blaster shoots bead-shaped media from a high-pressured tool towards the material's surface. A bead blast finish aims to leave a smooth, shiny, and cleaner surface.

#### RECOMMENDED BLASTING MEDIA

**20/40 Coarse Grade Garnet** is suitable for removal of thick coatings and extreme rust. 20-40 Garnet enables high productivity rates and an exceptional surface finish. Cuts the surface and is suitable for preparing surfaces for coating applications. Has Increased recyclability, reducing cost and waste.

**30/60 Mesh Premium Abrasive** is a versatile product for removal of medium to heavy grade coatings or rust. Can be used for a wide variety of applications. It enables high productivity rates and an exceptional surface finish. Is suitable for Steel or cast iron.

**-300/+106 Glass Beads** is one of the most popular forms of blast media and can be used on a variety of projects. Glass beads are used for general cleaning, peening and cosmetic finishing of sensitive metal surfaces. Achieves a smooth, bright finish. Glass beads are the best option where fine polished finishes are required. Glass beads are also recyclable and can be used up to 100 times before replacement, making them an extremely cost-effective option. Glass bead media works well on soft metals like aluminium and brass as well as plastic.

SANDBLASTING BEADS  
GARNET  
20 - 40 COARSE BEADS 25KG  
ORDER CODE S295



SANDBLASTING BEADS  
GARNET  
30 - 60 MEDIUM BEADS 25KG  
ORDER CODE S296



SANDBLASTING BEADS  
INDA-300 + 106 INDA (GLASS BEAD)  
25KG  
ORDER CODE S297



#### **WARNING!**

*When operating a Blast Cabinet it is important to wear appropriate safety gear to protect yourself from injury. This includes an approved safety respirator, to protect your chest and safety glasses to protect your eyes.*

## 5.4 TROUBLESHOOTING

1. **Blast Gun.** After 10 to 12 hours of blasting time, the Nozzle should be checked. If it shows uneven wear it should be turned 1/4 turn every 10 hours of use. Replace as needed.
2. **Caking of media.** Media caking is caused by moisture in the air supply or from oily or greasy parts. If not corrected the media will not flow evenly and will block the system. Check the air supply. If water is present, install a quality moisture trap. If oily or greasy parts are being blasted, degrease and dry the part first.
3. **Reverse pressure.** If the media stops flowing use an object to plug the Nozzle and press the Foot Pedal down for about two seconds. This will cause the system to back blast. This will help loosen any clogs. DO NOT use a finger to block the gun.
4. **Air supply.** If the pressure gauge on the regulator shows an adequate no-load supply (when the blaster is not running), press the foot pedal. If the pressure drops more than a few PSI your air supply is restricted or inadequate. Clean filters and moisture separators all the way back to the air compressor. Straighten any kinky lines. Use a master gauge to check the air pressure or replace existing gauge if you suspect it is giving you false readings.
5. **Blast Gun air pressure drop.** Turn the Air Regulator Knob and set the air pressure to 80 PSI as indicated on the Pressure Gauge. This could also indicate the air supply hose is too small, The air supply line should be 12mm diameter or larger.
6. **Poor visibility** (viewing window). The Glass Window is equipped with a clear plastic protector on it and may become pitted. If necessary, replace the plastic protector and/or Glass Window.
7. **Poor media flow.** Check for moisture. Holes in the media hose will also cause poor media delivery. If necessary, replace the hose. Debris in the media can also cause slow media flow. Replace or screen media.
8. **Dust collector.** Inadequate cabinet ventilation results in reduced cleaning power at the nozzle as well as diminished view of the work in progress. Use the dust collectors shaker every 20-30 minutes when the cabinet is turned off, (more often in dusty conditions. Empty dust collector at least once a day. Remove filter and blow out occasionally to keep the dust collector or vacuum working efficiently.  
Replace as needed.

## 6.0 MAINTENANCE

It is very important that regular maintenance of the equipment is carried out. The operators need to follow the daily maintenance procedures.

For optimum performance from this machine, the maintenance schedule listed below and in this section must be followed.

### 6.1 SCHEDULE

#### Daily Check

- Loose mounting bolts or fasteners.
- Worn, frayed, cracked, or damaged wires.
- Damaged ON/OFF switches
- Push the canister plunger and release to remove caked on dust in the filter.
- Check and clean if necessary filter cartridge
- Any other condition that could hamper the safe operation of this machine

#### Monthly Check:

- Check all fasteners and clamps are tight.
- Inspect suction lines carefully for spots that collapse or leak during operation.
- Clean/vacuum dust buildup from inside cabinet and off the motor.
- Empty cabinet, wipe down inside and inspect for leaks or damage.
- Cover windows and repaint bare metal portions of cabinet.
- Inspect work gloves for holes or wear.
- Remove the filter and clean or replace as require



### **WARNING!**

*When cleaning the cabinet or the filter, wear a respirator and safety goggles.  
Failure to comply can cause serious personal injury.*

**7.0 RECOMMENDED ACCESSORIES**

#42 - SANDBLASTING GUN

**Order Code: 6SC0042**



#12 - NOZZLES 4.0 MM PKT 2

**Order Code: 6SC0059**



#12 - NOZZLES 5.0MM PKT 2

**Order Code: 6SC0060**



#12 - NOZZLES 6.0MM PKT 2

**Order Code: 6SC0061**



#12 - NOZZLES 7.0MM PKT 2

**Order Code: 6SC0062**



Sandblasting Beads - Garnet  
30 - 60 Medium Beads (25kg)

**Order Code: S296**



Sandblasting Beads - Garnet  
20 - 40 Coarse Beads (25kg)

**Order Code: S295**



Sandblasting Beads - Inda  
-300 + 106 INDA (Glass Bead) (25kg)

**Order Code: S297**



#25 - PVC SHEET PKT 5 (MAIN WINDOW)

550MM x 250MM

**Order Code: SC004**



#15 - GLOVES PAIR

**Order Code: 2SC0035**



SB-C870 - Industrial Sandblasting  
Dust Cyclone Extractor  
2 Stage Filtration System

**Order Code: S310**



# SANDBLAST CABINET

## MODEL SB-220

Order Code: (S290)

The following section covers the spare parts diagrams and lists that were current at the time this manual was originally printed. Due to continuous improvements of the machine, changes may be made at anytime without notification.

### HOW TO ORDER SPARE PARTS

1. Have your machines model number, serial number & date of manufacture on hand, these can be found on the specification plate mounted on the machine.
2. A scanned copy of your parts list/diagram with required spare part/s identified.

**NOTE: SOME PARTS MAY ONLY BE AVAILABLE AS AN ASSEMBLY**

3. Go to [www.machineryhouse.com.au/contactus](http://www.machineryhouse.com.au/contactus) and fill out the inquiry form attaching a copy of scanned parts list.



### **WARNING!**

*Electricity is dangerous and could cause death.  
All electrical work must be carried out by a qualified electrician.*



### **CAUTION!**

*It is impossible to cover all possible hazards Every workshop environment is different. These are designed as a guide to be used to compliment training and as a reminder to users prior to equipment use. Always consider safety first, as it applies to the individual working conditions.*

**MACHINE - PARTS DIAGRAM**

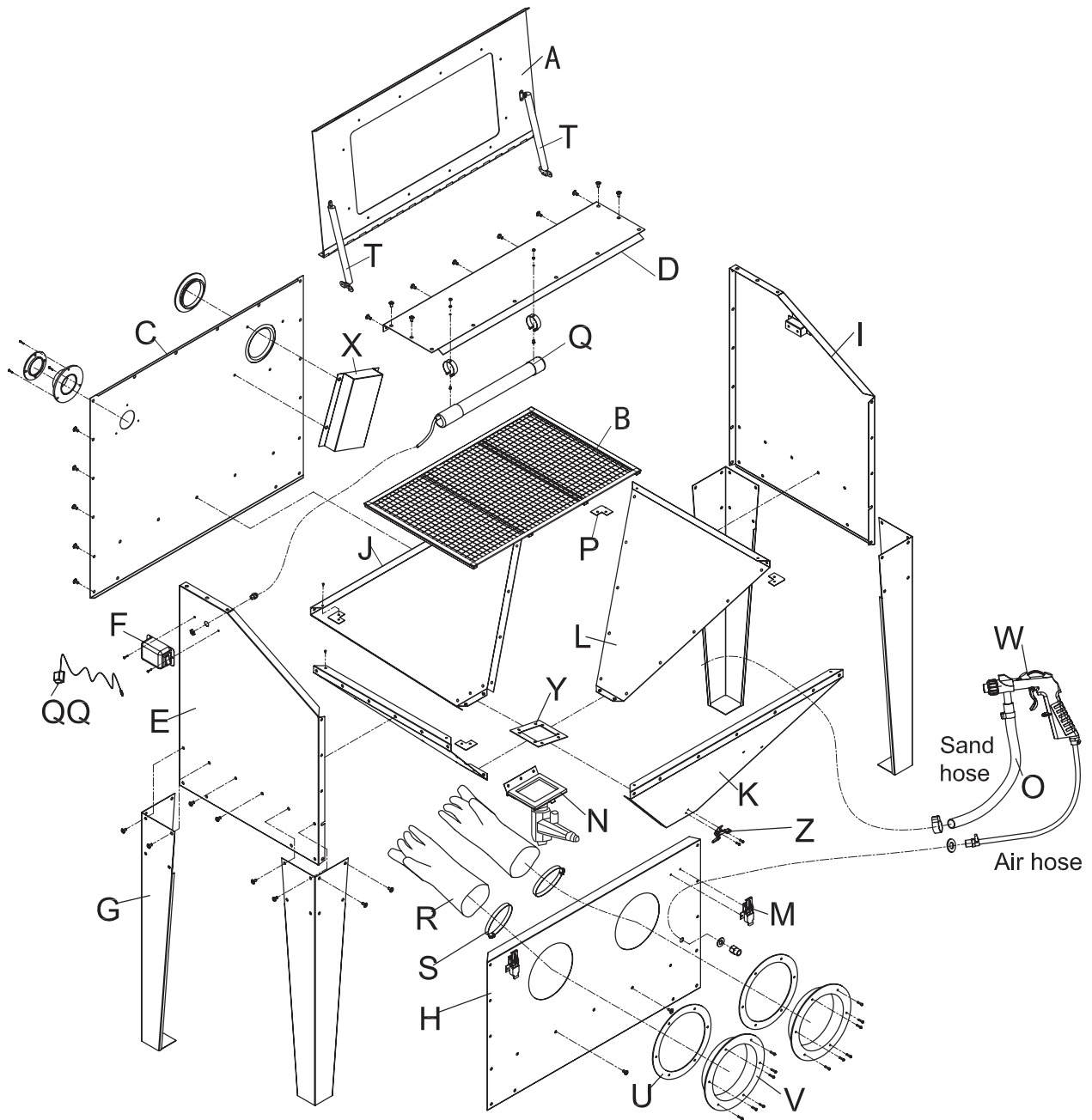

Part	Description	QTY	Part	Description	QTY	Part	Description	QTY
A	Top door assembly	1	J	Funnel back plate	1	S	Glove clamps	2
B	Work shelf	1	K	Funnel front plate	1	T	Door Air Struts	2
C	Back plate	1	L	Funnel side plate	2	U	Mounting ring of gloves	2
D	Top plate	1	M	Top door locker	2	V	Gloves seats	2
E	Left plate	1	N	Hatch & Met. Valve	1	w	Gun assembly	1
F	Switch Box	1	O	Pick-up hose	1	X	Sand boards	1
G	Foot	4	P	Bracket	4	Y	Funnel bottom plate	1
H	Front plate	1	Q	Lamp	1	Z	Funnel locker	1
I	Right plate	1	R	Glove	1 pair			



#### **ENVIRONMENT PROTECTION**

Recycle unwanted materials instead of disposing of them as waste. All tools, accessories and packaging should be sorted, taken to a recycling centre and disposed of in a manner which is compatible with the environment. When the product becomes completely unserviceable and requires disposal, drain any fluids (if applicable) into approved containers and dispose of the product and fluids according to local regulations.

IMPORTED BY

**HARE & FORBES**  
**MACHINERYHOUSE**

Australian Distributor

**Hare & Forbes**  
**Machineryhouse**  
Sydney - Melbourne  
Adelaide - Brisbane - Perth

**Ph: 1300 202 200**  
**[www.machineryhouse.com.au](http://www.machineryhouse.com.au)**

**MACHINERYHOUSE**

New Zealand Distributor

**Machineryhouse**  
Auckland  
Christchurch

**Ph: 0800 142 326**  
**[www.machineryhouse.co.nz](http://www.machineryhouse.co.nz)**